



# Intel<sup>®</sup> Galileo

## Board User Guide

---

*March 2014*



INFORMATION IN THIS DOCUMENT IS PROVIDED IN CONNECTION WITH INTEL PRODUCTS. NO LICENSE, EXPRESS OR IMPLIED, BY ESTOPPEL OR OTHERWISE, TO ANY INTELLECTUAL PROPERTY RIGHTS IS GRANTED BY THIS DOCUMENT. EXCEPT AS PROVIDED IN INTEL'S TERMS AND CONDITIONS OF SALE FOR SUCH PRODUCTS, INTEL ASSUMES NO LIABILITY WHATSOEVER AND INTEL DISCLAIMS ANY EXPRESS OR IMPLIED WARRANTY, RELATING TO SALE AND/OR USE OF INTEL PRODUCTS INCLUDING LIABILITY OR WARRANTIES RELATING TO FITNESS FOR A PARTICULAR PURPOSE, MERCHANTABILITY, OR INFRINGEMENT OF ANY PATENT, COPYRIGHT OR OTHER INTELLECTUAL PROPERTY RIGHT.

A "Mission Critical Application" is any application in which failure of the Intel Product could result, directly or indirectly, in personal injury or death. SHOULD YOU PURCHASE OR USE INTEL'S PRODUCTS FOR ANY SUCH MISSION CRITICAL APPLICATION, YOU SHALL INDEMNIFY AND HOLD INTEL AND ITS SUBSIDIARIES, SUBCONTRACTORS AND AFFILIATES, AND THE DIRECTORS, OFFICERS, AND EMPLOYEES OF EACH, HARMLESS AGAINST ALL CLAIMS COSTS, DAMAGES, AND EXPENSES AND REASONABLE ATTORNEYS' FEES ARISING OUT OF, DIRECTLY OR INDIRECTLY, ANY CLAIM OF PRODUCT LIABILITY, PERSONAL INJURY, OR DEATH ARISING IN ANY WAY OUT OF SUCH MISSION CRITICAL APPLICATION, WHETHER OR NOT INTEL OR ITS SUBCONTRACTOR WAS NEGLIGENT IN THE DESIGN, MANUFACTURE, OR WARNING OF THE INTEL PRODUCT OR ANY OF ITS PARTS.

Intel may make changes to specifications and product descriptions at any time, without notice. Designers must not rely on the absence or characteristics of any features or instructions marked "reserved" or "undefined". Intel reserves these for future definition and shall have no responsibility whatsoever for conflicts or incompatibilities arising from future changes to them. The information here is subject to change without notice. Do not finalize a design with this information.

The products described in this document may contain design defects or errors known as errata which may cause the product to deviate from published specifications. Current characterized errata are available on request.

Contact your local Intel sales office or your distributor to obtain the latest specifications and before placing your product order.

Copies of documents which have an order number and are referenced in this document, or other Intel literature, may be obtained by calling 1-800-548-4725, or go to: <http://www.intel.com/design/literature.htm>

Any software source code reprinted in this document is furnished for informational purposes only and may only be used or copied and no license, express or implied, by estoppel or otherwise, to any of the reprinted source code is granted by this document.

Intel processor numbers are not a measure of performance. Processor numbers differentiate features within each processor family, not across different processor families. Go to: [http://www.intel.com/products/processor\\_number/](http://www.intel.com/products/processor_number/)

Code Names are only for use by Intel to identify products, platforms, programs, services, etc. ("products") in development by Intel that have not been made commercially available to the public, i.e., announced, launched or shipped. They are never to be used as "commercial" names for products. Also, they are not intended to function as trademarks.

Intel and the Intel logo are trademarks of Intel Corporation in the U.S. and/or other countries.

\*Other names and brands may be claimed as the property of others.

Copyright © 2014, Intel Corporation. All rights reserved.



## Revision History

---

Date	Revision	Description
March 2014	001	Initial release of document.



## Contents

---

<b>1.0 Overview</b>	5
1.1 Key Components	5
<b>2.0 Details and Specifications</b>	8
2.1 Physical Characteristics	8
2.2 Electrical Summary	8
2.3 Schematic and Reference Design	8
2.4 Arduino Connector Pinout Details	9
2.4.1 Properties of Pins Configured as OUTPUT	10
2.4.2 I/O Pin Mappings	11
2.5 Jumpers	12
2.5.1 IOREF Jumper	13
2.5.2 I2C* Address Jumper	13
2.5.3 VIN Jumper	14
2.5.4 Force Recovery	14
2.6 Buttons	15
<b>3.0 Communication and Programming</b>	16
3.1 Communication	16
3.2 Programming	17
3.3 Automatic (Software) Reset	17
<b>4.0 Related Documentation</b>	18
<b>5.0 Galileo Disclaimer</b>	19

## Figures

1 Galileo - Front and Back Views	5
2 Key Components	6
3 Galileo Board Connection Diagram	9
4 Jumper Locations	13
5 Resistor Pin for Forcing Recovery	14
6 Reset Button and Reboot Button	15

## Tables

1 Description of Key Components	6
2 Galileo I/O Mappings	11
3 Galileo I/O Function Multiplexing	12
4 Related Documentation	18

§ §



## 1.0 Overview

The Intel® Galileo Board provides a programmable control PCB for the maker community, students, and professional developers. It is based on the Intel® Quark SoC X1000 Application Processor, a 32-bit Intel Pentium-class system on a chip.

The Intel® Galileo Board is the first board based on Intel® architecture designed to be hardware and software pin-compatible with Arduino shields designed for the Uno R3. It is also software-compatible with the Arduino\* Software Development Environment, making usability and development a snap.

In addition to Arduino hardware and software compatibility, the Intel® Galileo Board has several industry-standard I/O ports and features to expand native usage and capabilities beyond the Arduino shield ecosystem, which are described in the next section of this document.

**Figure 1. Galileo - Front and Back Views**

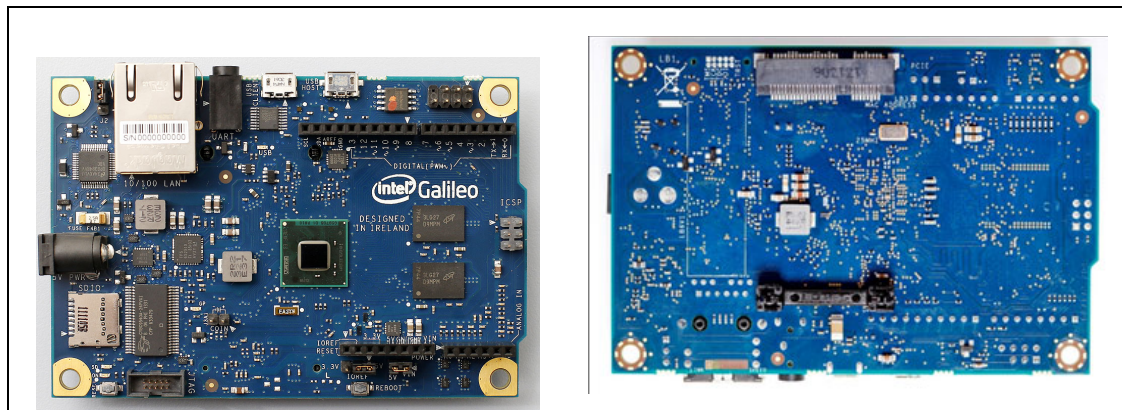

### 1.1 Key Components

Figure 2 and Table 1 describe key components of the Intel® Galileo Board.

Figure 2. Key Components

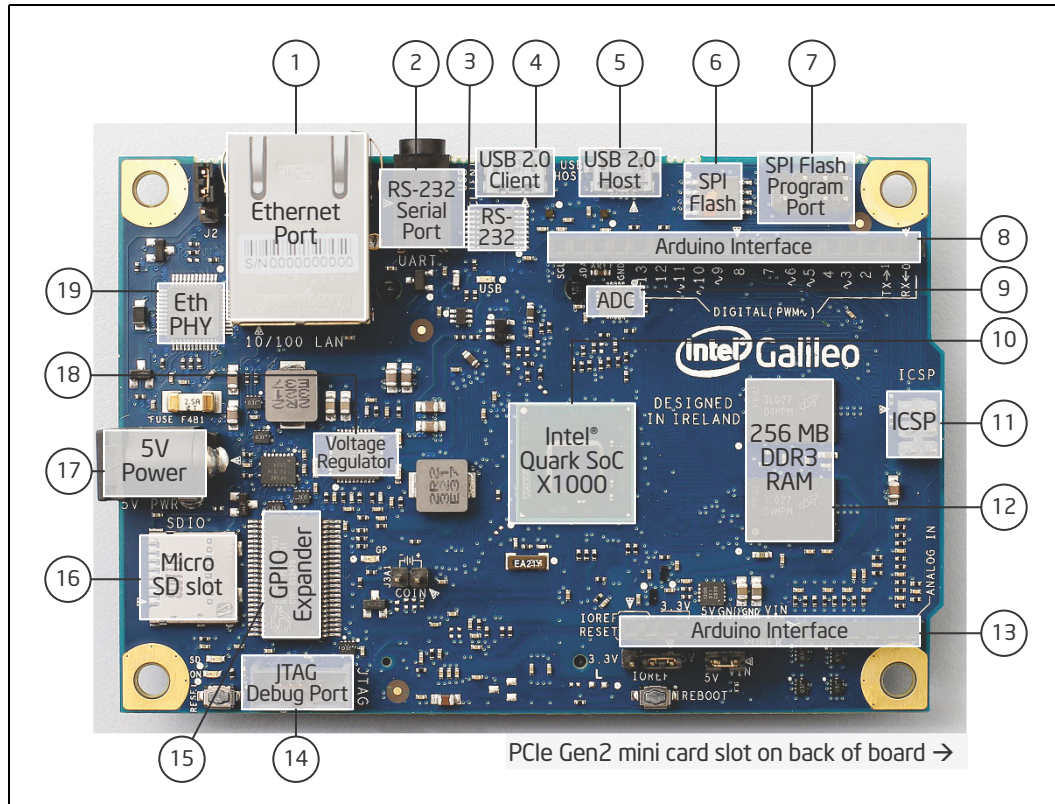

Table 1. Description of Key Components (Sheet 1 of 2)

Number	Component	Description
1	Ethernet Port	10/100 Ethernet connector
2	RS-232 Serial Port	3-pin 3.5mm jack (not audio)
3	RS-232	RS-232 transceiver
4	USB 2.0 Client	USB Client connector (Micro-USB Type B): a fully compliant USB 2.0 Device controller, typically used for programming
5	USB 2.0 Host	USB 2.0 Host connector (Micro-USB Type AB): supports up to 128 USB end point devices
6	SPI Flash	8 MByte Legacy SPI Flash to store the firmware (or bootloader) and the latest sketch.
7	SPI Flash Program Port	7-pin header for Serial Peripheral Interface (SPI) programming Defaults to 4 MHz to support Arduino Uno shields. Programmable up to 25 MHz. <b>Note:</b> The board has a native SPI controller, however, it will act as a master and not as an SPI slave. Therefore, it cannot be a SPI slave to another SPI master. It can act, however, as a slave device via the USB Client connector.
8	Shield Interface	Complies with Arduino Uno Revision 3 shield pinout. See <a href="#">Section 2.4</a> for details.
9	ADC	Analog to Digital converter



Table 1. Description of Key Components (Sheet 2 of 2)

Number	Component	Description
10	Intel® Quark SoC X1000	400 MHz 32-bit Intel® Pentium instruction set architecture (ISA)-compatible processor <ul style="list-style-type: none"> <li>• 16 KByte L1 cache</li> <li>• 512 KBytes of on-die embedded SRAM</li> <li>• Simple to program: Single thread, single core, constant speed</li> <li>• ACPI compatible CPU sleep states supported</li> <li>• An integrated Real Time Clock (RTC), with an optional 3V "coin cell" battery for operation between turn on cycles.</li> </ul>
11	ICSP	6-pin in-circuit serial programming (ICSP) header, located appropriately to plug into existing shields. These pins support SPI communication using the SPI library.
12	256 MB DDR3 RAM	256 MByte DRAM, enabled by the firmware by default.
13	Arduino Interface	Complies with Arduino Uno Revision 3 pinout. See <a href="#">Section 2.4</a> for details.
14	JTAG Debug Port	10-pin standard JTAG header for debugging
15	GPIO Expander	GPIO pulse width modulation provided by a single I <sup>2</sup> C I/O expander
16	Micro SD slot	(Optional) Supports micro SD card up to 32 GBytes
17	5V Power	The board is powered via an AC-to-DC adapter, connected by plugging a 2.1 mm center-positive plug into the board's power jack. The recommended output rating of the power adapter is 5V at up to 3A.
18	Voltage Regulator	Generates 3.3 volt supply. Maximum current draw to the shield is 800 mA.
19	Eth PHY	Ethernet Physical layer transceiver
On back of board, see <a href="#">Figure 1</a> .		Full PCI Express* mini-card slot, with PCIe* 2.0 compliant features: <ul style="list-style-type: none"> <li>• Works with half mini-PCIe* cards with optional converter plate</li> <li>• Provides USB 2.0 Host Port at mini-PCIe* connector</li> </ul>



## 2.0 Details and Specifications

---

### 2.1 Physical Characteristics

The Intel® Galileo Board is 10 cm long and 7 cm wide respectively, with the USB connectors, UART jack, Ethernet connector, and power jack extending beyond the former dimension. Four screw holes (4 mm diameter) allow the board to be attached to a surface or case.

*Note:* The distance between digital pins 7 and 8 is 160 mil (0.16"); it is not an even multiple of the 100 mil spacing of the other pins.

### 2.2 Electrical Summary

The Intel® Galileo Board is powered via an AC-to-DC adapter, connected by plugging a 2.1 mm center-positive plug into the board's power jack. The recommended output rating of the power adapter is 5V at up to 3A.

Input Voltage (recommended)	5V
Input Voltage (limits)	5V
Digital I/O Pins	14 (of which 6 provide PWM output)
Analog Input Pins	6
Total DC Output Current on all I/O lines	80 mA
DC Current for 3.3V Pin	800 mA
DC Current for 5V Pin	800 mA

### 2.3 Schematic and Reference Design

Figure 3 shows a connection diagram for the Intel® Galileo Board.

For complete board details, see:

- Galileo Schematic in PDF:  
<https://communities.intel.com/docs/DOC-21822>
- Galileo Reference Design: zip file containing Allegro Board file  
<https://communities.intel.com/docs/DOC-21824>





Figure 3. Galileo Board Connection Diagram

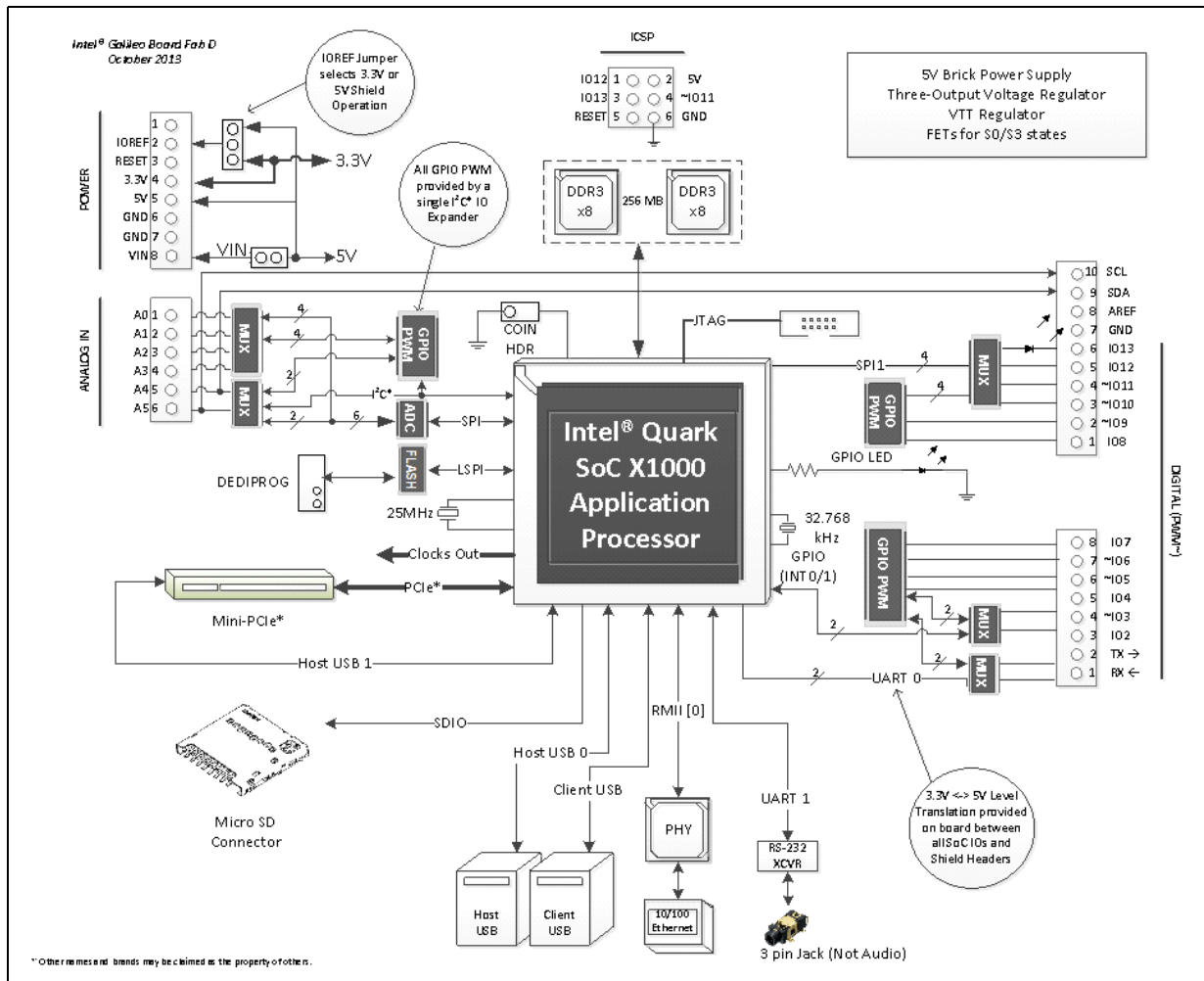

## 2.4 Arduino Connector Pinout Details

The Intel® Galileo Board is designed to support shields that operate at either 3.3V or 5V. The core operating voltage of Intel® Galileo Board is 3.3V; however, a jumper on the board enables voltage translation to 5V at the I/O pins. See [Section 2.5.3, “VIN Jumper”](#) on page 14 for details.

The Intel® Galileo Board complies with the Arduino Uno Revision 3 pinout as follows:

- 14 digital input/output pins (IO2-IO13, TX, RX):
  - Each of the 14 digital pins on Galileo can be used as an input or output, using pinMode(), digitalWrite(), and digitalRead() functions.
  - The pins operate at 3.3 volts or 5 volts. Each pin can source a max of 10 mA or sink a maximum of 25 mA and has an internal pull-up resistor (disconnected by default) of 5.6 k to 10 kOhms.



- 6 digital pins can be used as Pulse Width Modulation (PWM) outputs; they are labeled with the ~ symbol. See [Section 2.4.2, “I/O Pin Mappings” on page 11](#) for details.
- The RX and TX pins control the programmable speed UART port.
- SCL and SDA pins control the I<sup>2</sup>C\* bus.  
TWI: A4 or SDA pin and A5 or SCL pin. TWI communication is supported via the Arduino Wire library.
- AREF is unused. Providing an external reference voltage for the analog inputs is not supported.  
**Note:** It is not possible on the Intel® Galileo Board to change the upper end of the analog input range using the AREF pin and the analogReference() function.
- 6 analog input pins (A0-A5):
  - Each one of the 6 analog input pins provides 12 bits of resolution (that is, 4096 different values). By default, they measure from ground to 5 volts.
- 7 power pins:
  - IOREF: The IOREF pin allows an attached shield with the proper configuration to adapt to the voltage provided by the board. The IOREF pin voltage is controlled by a jumper on the board, i.e., a selection jumper on the board is used to select between 3.3 V and 5 V shield operation.
  - RESET button/pin: Bring this line LOW to reset the sketch. Typically used to add a reset button to shields that block the one on the board.
  - 3.3V output pin: A 3.3 Volt supply generated by the on-board regulator. Maximum current draw to the shield is 800 mA.
  - 5V output pin: This pin outputs 5 V from the external source or the USB connector. Maximum current draw to the shield is 800 mA.
  - GND (2 pins): Ground pins.
  - VIN: The input voltage to the Intel® Galileo Board when it is using an external power source (as opposed to 5 Volts from the regulated power supply connected at the power jack). You can supply voltage through this pin, or, if supplying voltage via the power jack, access it through this pin.  
**Note:** The voltage applied to this pin must be a regulated 5 V supply, otherwise it could damage the Intel® Galileo Board or cause incorrect operation.

### 2.4.1 Properties of Pins Configured as OUTPUT

Pins configured as OUTPUT with pinMode() are said to be in a low-impedance state. On the Intel® Galileo Board, when a pin is configured as OUTPUT, the functionality is provided via an I<sup>2</sup>C\*-based Cypress I/O expander. Digital pins 0 to 13 and Analog pins A0 to A5 can be configured as OUTPUT pins on the Intel® Galileo Board.

The I/O expander's pins, when configured as OUTPUT, can source (provide positive current) up to 10 mA (milliamps) and can sink (provide negative current) up to 25 mA of current to other devices/circuits. The individual per pin current sourcing capability of 10 mA is subject to an overall limit of 80 mA combined between all OUTPUT pins. The per pin capability current sinking capability is subject to an overall limit of 200 mA. The table below provides a breakdown of the overall OUTPUT capabilities of the pins.



	Current Source (mA)	Current Sink (mA)
Per Pin Capability	10	25
Digital Pins 3,5,9,10,12, 13 Combined	40	100
Digital Pins 0,1,2,4,6,7,8,11 and Analog Pins A0,A1,A2,A3,A4, A5 Combined	40	100
Digital Pins 0-13 and Analog Pins A0-A5 Combined	80	200

## 2.4.2 I/O Pin Mappings

Table 2. Galileo I/O Mappings

Arduino IDE ID	GPIO			PWM	Int	Dir	Muxed with	Initial Setup
	Source	Pin	Linux	Linux				
IO0	Cypr	GPORT4_BIT6_PWM2	50	N/A	-	BI	UART0_RXD	I w/ pullup off
IO1	Cypr	GPORT4_BIT7_PWM0	51	N/A	-	BI	UART0_TXD	I w/ pullup off
IO2	SoC (Cypr)	GPIO<6> (GPORT2_BIT0_PWM6_A3)	14 (32*)	-	0	BI	-	I w/ pullup off
IO3	SoC (Cypr)	GPIO<7> (GPORT0_BIT2_PWM3)	15 (18*)	3	1	BI	(PWM)	I w/ pullup off
IO4	Cypr	GPORT1_BIT4_PWM6	28		-	BI	-	I w/ pullup off
IO5	Cypr	GPORT0_BIT1_PWM5	17	5	-	BI	(PWM)	I w/ pullup off
IO6	Cypr	GPORT1_BIT0_PWM6	24	6	-	BI	(PWM)	I w/ pullup off
IO7	Cypr	GPORT1_BIT3_PWM0	27		-	BI	-	I w/ pullup off
IO8	Cypr	GPORT1_BIT2_PWM2	26		-	BI	-	I w/ pullup off
IO9	Cypr	GPORT0_BIT3_PWM1	19	1	-	BI	(PWM)	I w/ pullup off
IO10	Cypr	GPORT0_BIT0_PWM7	16	7	-	BI	(PWM) SPI1_SS_B	I w/ pullup off
IO11	Cypr	GPORT1_BIT1_PWM4	25	4	-	BI	(PWM) SPI1_MOSI	I w/ pullup off
IO12	Cypr	GPORT3_BIT2_PWM3	38		-	BI	SPI1_MISO	I w/ pullup off
IO13	Cypr	GPORT3_BIT3_PWM1	39		-	BI	SPI1_SCK	I w/ pullup off
IO14	Cypr	GPORT4_BIT0_PWM6	44		-	BI	AD7298:VIN0	I w/ pullup off
IO15	Cypr	GPORT4_BIT1_PWM4	45		-	BI	AD7298:VIN1	I w/ pullup off
IO16	Cypr	GPORT4_BIT2_PWM2	46		-	BI	AD7298:VIN2	I w/ pullup off
IO17	Cypr	GPORT4_BIT3_PWM0	47		-	BI	AD7298:VIN3	I w/ pullup off
IO18	Cypr	GPORT4_BIT4_PWM6	48		-	BI	AD7298:VIN4	I w/ pullup off
IO19	Cypr	GPORT4_BIT5_PWM4	49		-	BI	AD7298:VIN5	I w/ pullup off



**Table 3. Galileo I/O Function Multiplexing**

Mux Selector		Cypress GPIO Pin	Linux GPIO ID	Dir	Initial Setup
0	1				
UART0_RXD	IO0	GPORT3_BIT4_PWM7	40	O	unknown
UART0_TXD	IO1	GPORT3_BIT5_PWM5	41	O	unknown
SPI1_SS_B	IO10	GPORT3_BIT6_PWM3	42	O	unknown
SPI1_MOSI	IO11	GPORT3_BIT7_PWM1	43	O	unknown
SPI1_MISO	IO12	GPORT5_BIT2_PWM3	54	O	unknown
SPI1_SCK	IO13	GPORT5_BIT3_PWM1	55	O	unknown
AD7298:VIN0	IO14	GPORT3_BIT1_PWM5	37	O	0
AD7298:VIN1	IO15	GPORT3_BIT0_PWM7	36	O	0
AD7298:VIN2	IO16	GPORT0_BIT7_PWM1	23	O	0
AD7298:VIN3	IO17	GPORT0_BIT6_PWM3	22	O	0
AD7298:VIN4	IO18	GPORT0_BIT5_PWM5	21	O	0
AD7298:VIN5	IO19	GPORT0_BIT4_PWM7	20	O	0
IO2 via SoC GPIO<6>	IO2 via Cypress GPORT2_BIT0_PWM6	GPORT1_BIT7_PWM0	31	O	unknown
IO3 via SoC GPIO<7>	IO3 via Cypress GPORT0_BIT2_PWM3	GPORT1_BIT6_PWM2	30	O	unknown
I2C	(AD7298:VIN4 or IO18) and (AD7298:VIN5 or IO19)	GPORT1_BIT5_PWM4	29	O	1

## 2.5 Jumpers

This section describes the jumpers on Galileo that are used to vary the configuration of the board.

Figure 4. Jumper Locations

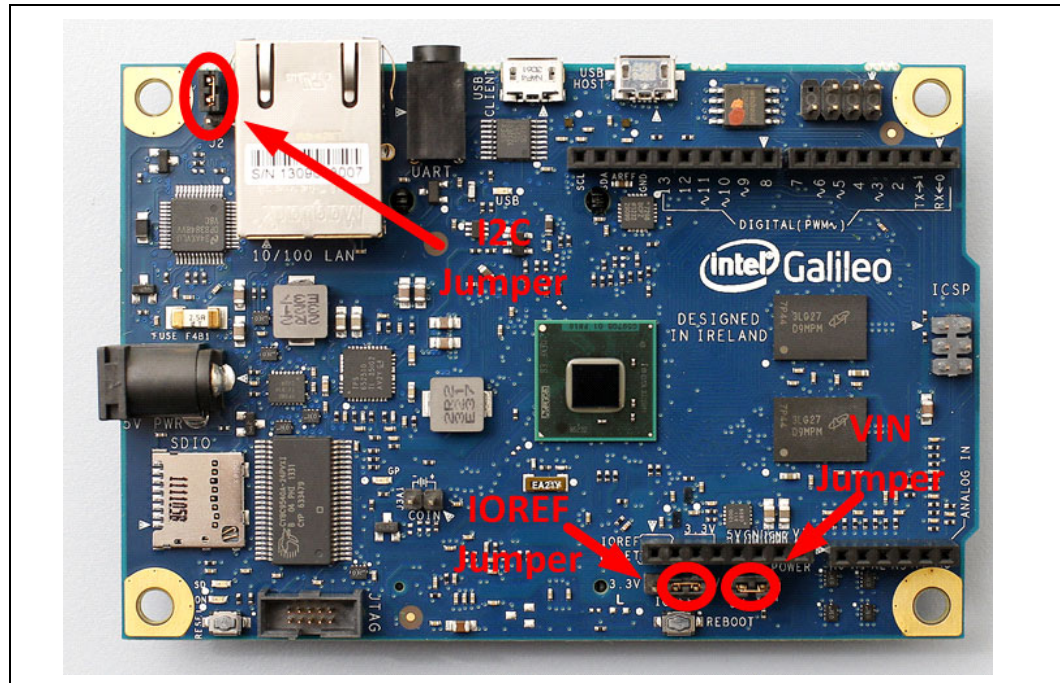

### 2.5.1 IOREF Jumper

To support both 3.3 V and 5 V shields, the external operating voltage is controlled via a jumper.

- When the jumper is connected to 5 V, the board is configured to be compatible with 5 V shields and IOREF is set to 5 V.
- When the jumper is connected to 3.3 V, the board is configured to be compatible with 3.3 V shields and IOREF is set to 3.3 V.

The input range of the Analog pins is also controlled by the IOREF jumper and must not exceed the chosen operating voltage. However, the resolution of AnalogRead() remains at 5 V/1024 units for the default 10-bit resolution or, 0.0049 V (4.9 mV) per unit regardless of IOREF jumper setting.

**Warning:** The IOREF jumper should be used to match the board and shield operating voltages. Incorrectly setting the voltage could damage the board or the shield.

### 2.5.2 I<sup>2</sup>C\* Address Jumper

To prevent a clash between the I<sup>2</sup>C\* Slave address of the on board I/O expander and EEPROM with any external I<sup>2</sup>C\* Slave devices, jumper J2 can be used to vary the I<sup>2</sup>C\* address of the on-board devices.

With J2 connected to pin 1 (marked with white triangle), the 7-bit I/O Expander address is 0100001 and the 7-bit EEPROM address is 1010001.

Changing the jumper position changes the I/O Expander address to 0100000 and the EEPROM address to 1010000.

### 2.5.3 VIN Jumper

The VIN pin can be used to supply 5 V from the regulated power supply connected at the power jack to attached shields or devices. If there is a need to supply more than 5 V to a shield using VIN, then the VIN jumper should be removed from the board to break the connection between the on-board 5 V supply and the VIN connection on the board header.

**Warning:** If the VIN jumper is not removed and more than 5 V is connected to VIN, it may damage the board or lead to unreliable operation.

### 2.5.4 Force Recovery

If your Intel® Galileo Board is in an unbootable state, you can force recovery to recover the contents of the SPI flash. For example, if power was lost during a normal firmware update, the board would be unbootable and this procedure would be necessary. You will need to ground a resistor pin as described below.

Figure 5. Resistor Pin for Forcing Recovery

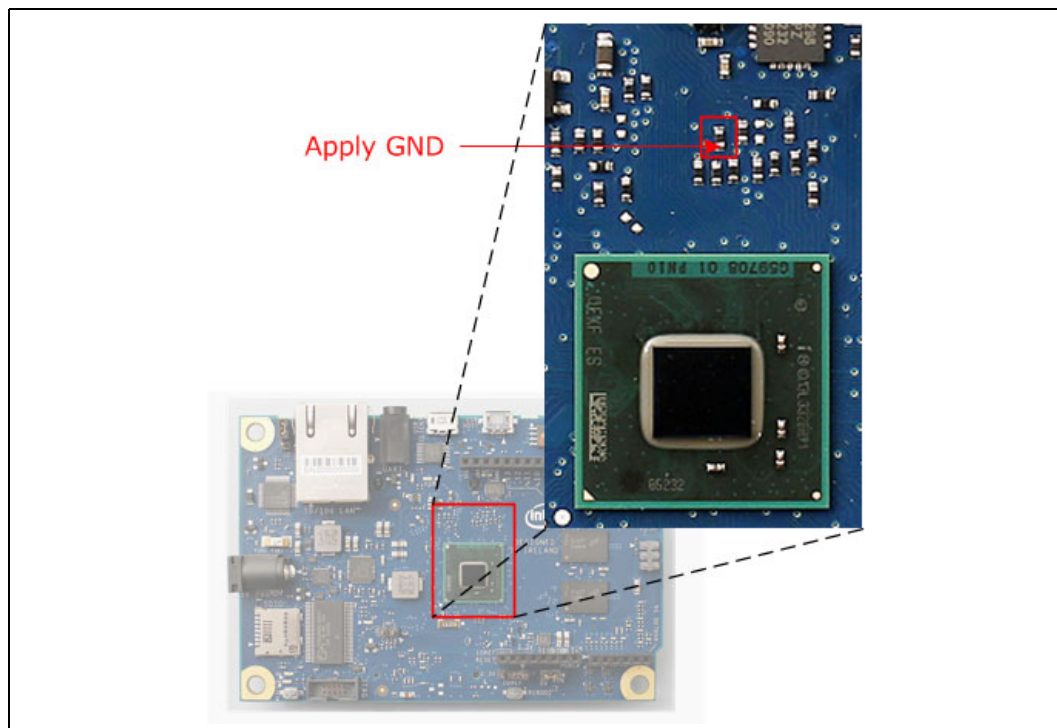

Boot the firmware in recovery mode by performing the following steps:

1. Copy a SPI Flash recovery file (the `FVMAIN.ev` file described in the [\[Build Guide\]](#)) to the root directory of a USB key. Insert the USB key into the board.
2. Connect the serial cable between the computer and the board's RS-232 serial port (see [Figure 2](#)). Set up a serial console session (for example, PuTTY) and connect to the board's COM port at 115200 baud rate.
3. Remove power from the board.
4. Make a connection from ground to the resistor pin shown in [Figure 5](#) (resistor R2B16).
5. Connect power to the board.







## 3.0 Communication and Programming

---

### 3.1 Communication

The Intel® Galileo Board has a number of facilities for communicating with a computer, another Arduino board, or other microcontrollers.

#### UART

The board provides UART TTL (5 V/3.3 V) serial communication, which is available on digital pin 0 (RX) and 1 (TX). In addition, a second UART provides RS-232 support and is connected via a 3.5 mm jack.

#### USB Client Ports

The USB Client ports allows for serial (CDC-ACM) communications over USB. This provides a serial connection to the Serial Monitor or other applications on your computer. It is also used to upload sketches to the board.

#### USB Host Port

The USB Host port allows the board to act as a USB Host for connected peripherals such as mice, keyboards, and smartphones.

#### mini PCI Express\* (mPCIe\*)

The Intel® Galileo Board is the first Arduino board to provide a mini PCI Express\* (mPCIe\*) slot. This slot allows full size and half size (with adapter) mPCIe\* modules to be connected to the board and also provides an additional USB Host port via the mPCIe\* slot. Any standard mPCIe\* module can be connected and used to provide applications such as WiFi, Bluetooth or Cellular connectivity. Initially, the mPCIe\* slot provides support for the WiFi Library. For additional information, see the Intel® Galileo Board Getting Started Guide ([\[GSG\]](#) in [Table 4](#)).

#### Ethernet RJ45

An Ethernet RJ45 Connector is provided to allow the board to connect to wired networks. Full support of on-board Ethernet interface is fully supported and does not require the use of the SPI interface like existing Arduino shields.

#### microSD card reader

The onboard microSD card reader is accessible through the Arduino SD Library. The communication between the board and the SD card is provided by an integrated SD controller and does not require the use of the SPI interface like other Arduino boards. The native SD interface runs at up to 50 MHz depending on the class of card used.

#### TWI/I<sup>2</sup>C\*

The Arduino software includes a Wire library to simplify use of the TWI/I<sup>2</sup>C\* bus; see the Arduino documentation for details.

#### SPI

For SPI communication, use the Arduino SPI library.





## 3.2 Programming

Use the Arduino Software Development Environment to create programs, called sketches, for the Intel® Galileo Board. To run a sketch on the board:

1. Connect a power supply.
2. Connect the board's USB client port to a computer.
3. Upload the sketch using the IDE interface.

The sketch runs on the Intel® Galileo Board and communicates with the Linux\* kernel in the board's firmware using the Arduino I/O adapter. For complete details on programming your board, see the Intel® Galileo Board Getting Started Guide ([Table 4](#)).

When the board boots up, two scenarios are possible:

- If a sketch is present in persistent storage, it is executed.
- If no sketch present, the board waits for upload commands from the IDE.

If a sketch is executing, you can upload from the IDE without having to press the reset button on the board. The sketch is stopped; the IDE waits for the upload state, and then starts the newly uploaded sketch.

Pressing the reset button on the board restarts a sketch if it is executing and resets any attached shields.

## 3.3 Automatic (Software) Reset

Rather than requiring a physical press of the reset button before an upload, the Intel® Galileo Board is designed in a way that allows it to be reset by software running on a connected computer. USB CDC-ACM control signals are used to transition the board from run-time to bootloader mode. The Arduino software uses this capability to allow you to upload code by simply pressing the upload button in the Arduino environment. For details, see the Intel® Galileo Board Getting Started Guide ([Table 4](#)).



## 4.0 Related Documentation

---

**Table 4. Related Documentation**

Title	Number	Reference
Intel® Galileo Board Getting Started Guide <a href="https://communities.intel.com/docs/DOC-22204">https://communities.intel.com/docs/DOC-22204</a>	329685	[GSG]
Intel® Galileo Software Release Notes <a href="https://communities.intel.com/docs/DOC-21837">https://communities.intel.com/docs/DOC-21837</a>	328686	[Gal RN]
Galileo Schematic <a href="https://communities.intel.com/docs/DOC-21822">https://communities.intel.com/docs/DOC-21822</a>	n/a	[Schematic]
Galileo Reference Design <a href="https://communities.intel.com/docs/DOC-21824">https://communities.intel.com/docs/DOC-21824</a>	n/a	[Ref Design]
Intel® Quark SoC X1000 Board Support Package (BSP) Build and Software User Guide	329687	[Build Guide]



## 5.0 Galileo Disclaimer

---

### Intel® Galileo Design Document

This Intel® Galileo design document is licensed by Intel under the terms of the Creative Commons Attribution Share-Alike License (ver. 3), subject to the following terms and conditions. The Intel® Galileo design document IS PROVIDED "AS IS" AND "WITH ALL FAULTS." Intel DISCLAIMS ALL OTHER WARRANTIES, EXPRESS OR IMPLIED REGARDING THE GALILEO DESIGN OR THIS GALILEO DESIGN DOCUMENT INCLUDING, BUT NOT LIMITED TO, ANY IMPLIED WARRANTIES OF MERCHANTABILITY OR FITNESS FOR A PARTICULAR PURPOSE.

Intel® may make changes to the specifications, schematics and product descriptions at any time, without notice. The Customer must not rely on the absence or characteristics of any features or instructions marked "reserved" or "undefined." Intel® reserves these for future definition and shall have no responsibility whatsoever for conflicts or incompatibilities arising from future changes to them. ENJOY!

§ §